



宏钰电子（嘉善）有限公司
HONGYU ELECTRICAL (JIASHAN) CO.,LTD.

Add:No,69 Jinxiu Road East City Development Zone,
Jiashan,Zhejiang,China
Tel:86 573 84062088 , 84062188
Fax:86 573 84062898
http://www.hongyuzj.com
E-mail:henry@hongyuzj.com

AC SOCKET



SS-120-0.8A-4.8

STANDARD:IEC 320 C14

RATING:15A/250V AC

APPROVALS:UL/CSA

RATING:10A250V~

APPROVALS:VDE/KEMA/SEV/DEMKO/NEMKO/
SEMKO/FIMKO/CCEE

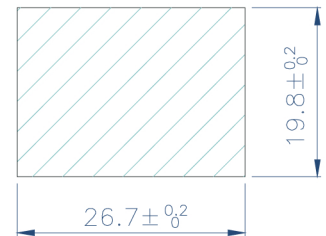
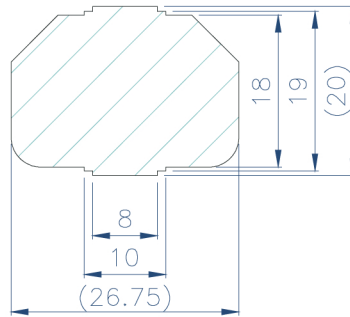
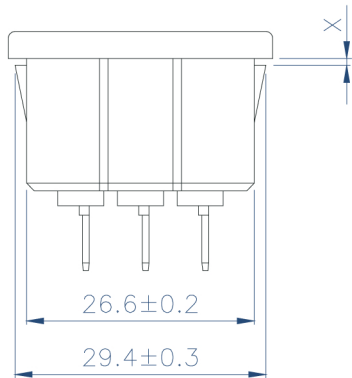
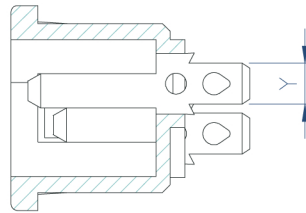
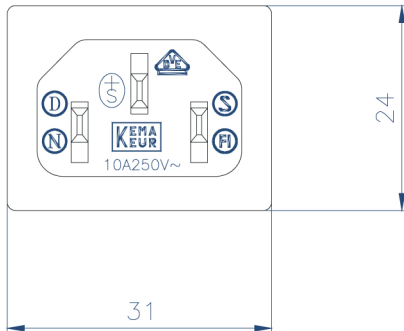

PANEL CUTOUT

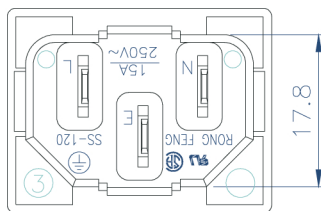

	X	Y	MODE
SS-120	0.8A-	6.3	
	1.0A-	4.8	
	1.5A-	4.0	
	2.0A-	2.8	